

TWENTRIPRISES, INC.

800-955-3795

TWE GEN Controls Diagram

- 0 - White
- 1 - Black
- 2 - White/Black
- 3 - Orange
- 4 - Pink
- 5 - Green
- 6 - Yellow
- 7 - White/Yellow
- 8 - White/Purple
- 9 - Gray
- 10 - Blue
- 11 - Red
- 12 - Purple
- 13 - Brown

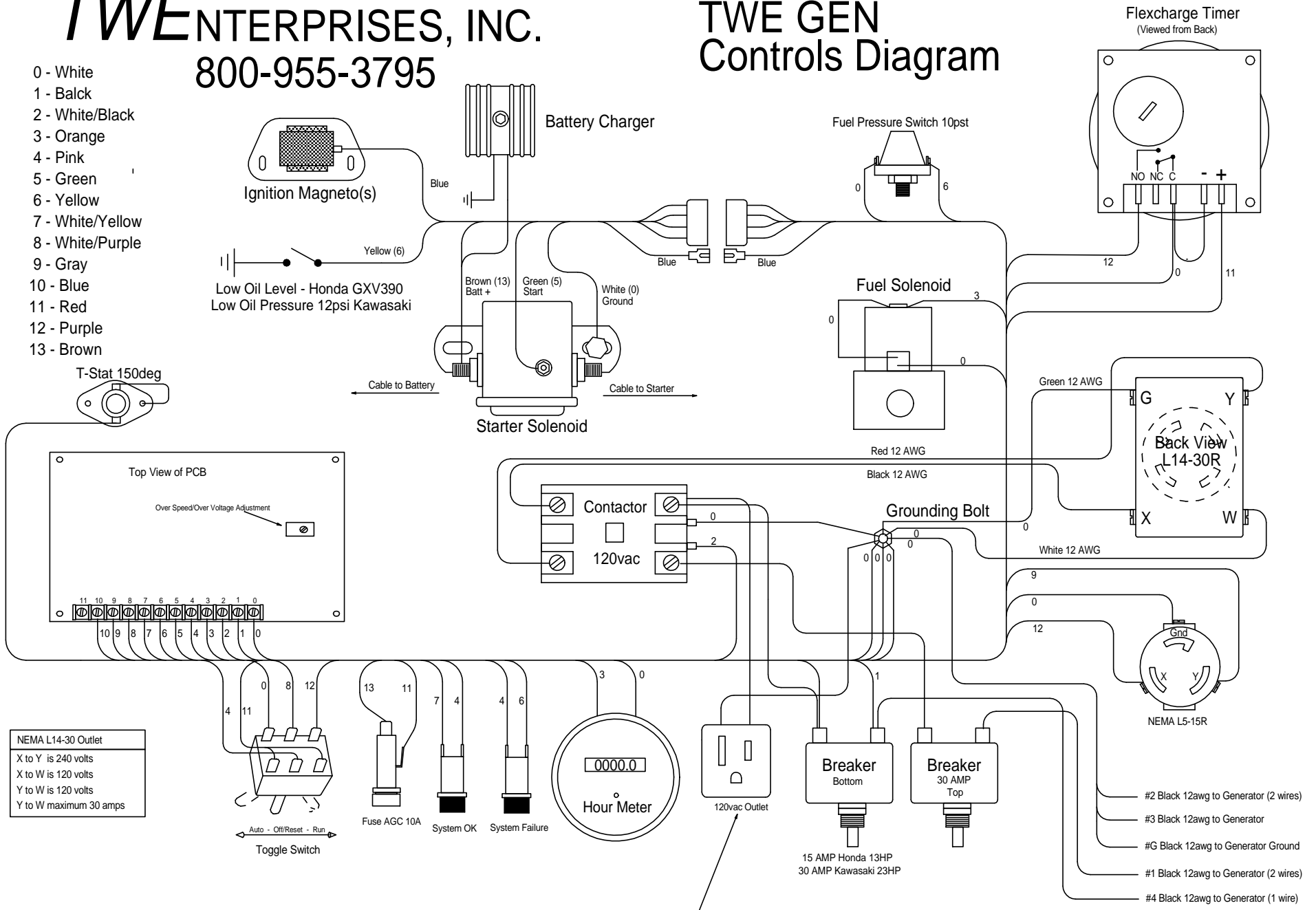

NEMA L14-30 Outlet
 X to Y is 240 volts
 X to W is 120 volts
 Y to W is 120 volts
 Y to W maximum 30 amps

Flexcharge Timer
(Viewed from Back)

Back View
L14-30R

Note: Kawasaki has 15AMP Fuse Link inside Control Panel

- #2 Black 12awg to Generator (2 wires)
- #3 Black 12awg to Generator
- #G Black 12awg to Generator Ground
- #1 Black 12awg to Generator (2 wires)
- #4 Black 12awg to Generator (1 wire)